

FlipSled® Training Sled **(also known as Pancake Sled™ Training Sled)** **by The Finisher®** **Owner's Manual**

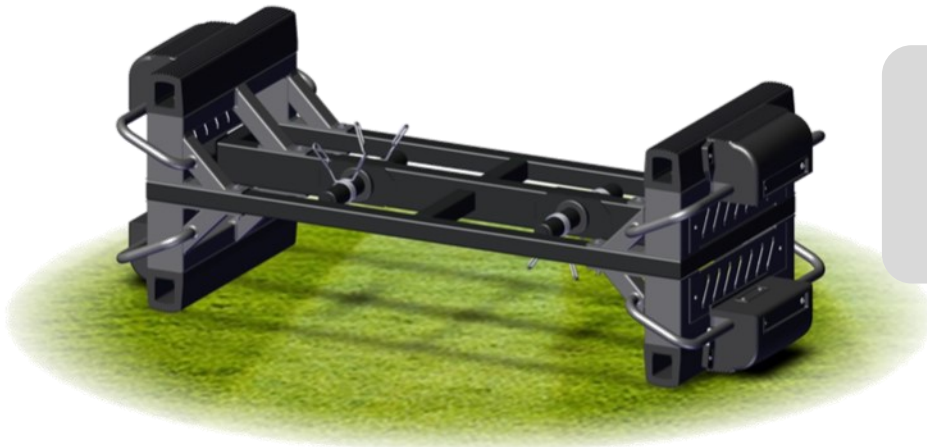

FlipSled®
FS300



FlipSled®
FS200

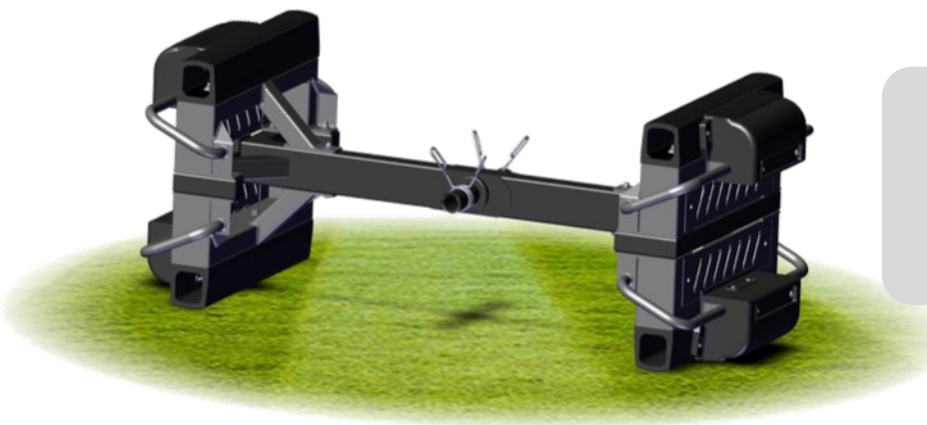

FlipSled®
FS100

Trademarks: Pancake Crew™ , Pancake™

SPECIFICATIONS

2

Product Specifications

Product Dimensions

FS300	67.2in x 30in x 24in (LxWxH) 170.7cm x 76.2cm x 61cm (LxWxH)
FS200	67.2in x 30in x 24in (LxWxH) 170.7cm x 76.2cm x 61cm (LxWxH)
FS100	61.2in x 30in x 24in (LxWxH) 155.5cm x 76.2cm x 61cm (LxWxH)

Product Weight, Unloaded

FS300	260 lbs (118 kgs)
FS200	200 lbs (91 kgs)
FS100	190 lbs (85 kgs)

Product Weight, Max Load

FS300	690 lbs (313 kgs)
FS200	450 lbs (204 kgs)
FS100	350 lbs (159 kgs)



READ AND SAVE THESE INSTRUCTIONS

IMPORTANT SAFETY INSTRUCTIONS

3

1. **SERIOUS INJURY OR DEATH CAN OCCUR WHILE USING THIS EQUIPMENT. READ AND FOLLOW ALL PRODUCT WARNINGS AND INSTRUCTIONS, AND RECEIVE PROPER INSTRUCTION OR TRAINING PRIOR TO USING THE FLIPSLED® TO REDUCE THE RISK OF POTENTIAL SERIOUS INJURY OR DEATH.**
2. **THE FLIPSLED® IS CONSIDERED HEAVY STRENGTH TRAINING EQUIPMENT AND CAN CAUSE SERIOUS INJURY OR DEATH IF NOT USED PROPERLY OR IF YOU FAIL TO FOLLOW THESE SAFETY INSTRUCTIONS.**
3. **ALWAYS USE SPOTTERS TO REDUCE THE RISK OF SERIOUS INJURY OR DEATH.**
4. **ALL USERS, SPOTTERS, AND BYSTANDERS MUST REMAIN CLEAR FROM UNDERNEATH THE FLIPSLED® AND CLEAR FROM THE PATH OF THE FLIPSLED® AT ALL TIMES WHILE IN USE AND KEEP A PROPER LOOKOUT TO REDUCE THE RISK OF SERIOUS INJURY OR DEATH.**
5. **MAINTAIN ADEQUATE DISTANCE BETWEEN FLIPSLEDS®, USERS AND SPOTTERS WHEN MULTIPLE FLIPSLEDS® ARE BEING USED SIMULTANEOUSLY, TO AVOID RISK OF SERIOUS INJURY OR DEATH.**
6. **WHILE DRIVING AND FLIPPING THE FLIPSLED®, USERS SHOULD NEVER HOLD ON TO THE FLIPSLED® AS IT ROTATES AND FALLS TO THE GROUND. IF YOU LOSE CONTROL OF THE FLIPSLED®, LET GO AND MOVE AWAY FROM THE FALLING FLIPSLED® TO REDUCE THE RISK OF SERIOUS INJURY OR DEATH.**
7. **BE AWARE OF OTHERS TRAINING NEAR THIS EQUIPMENT. THERE IS A CHANCE THAT THE FLIPSLED® MAY SHIFT Laterally OR LONGITUDINALLY WHEN DRIVING OR FLIPPING IS PERFORMED NOT STRAIGHT OR IS PERFORMED AT AN ANGLE OR WHERE THE GROUND IS UNEVEN. THIS MAY LEAD TO INADVERTENT CONTACT BETWEEN THE FLIPSLED® AND USERS, SPOTTERS OR BYSTANDERS WHICH COULD LEAD TO SERIOUS INJURY OR DEATH. ALWAYS ENSURE OTHERS ARE CLEAR OF THE FLIPSLED® AND BE AWARE OF OTHER USERS, SPOTTERS AND BYSTANDERS WHEN IN THE AREA A FLIPSLED® IS BEING USED. USERS AND SPOTTERS SHOULD DISCUSS SAFE AND PROPER USE TECHNIQUES WITH YOUR INSTRUCTOR OR TRAINERS TO REDUCE THE POTENTIAL OF SERIOUS INJURY OR DEATH SHOULD YOU LOSE CONTROL OF THE FLIPSLED® WHILE IN USE.**

⚠ CAUTION ⚠ ATTENTION

**This Is Not A Toy and Intended for Use By or Under the Supervision of Adults.
Ceci n'est pas un jouet et est destiné à être utilisé par ou sous la surveillance d'adultes.**

IMPORTANT SAFETY INSTRUCTIONS CONT.

4

8. **DO NOT DROP FLIPSLED® ON ITS SKIS OR FLIP FLIPSLED® ONTO ITS SKIS. THESE ACTIONS CAN LEAD TO UNINTENDED MOVEMENT OF THE SLED WHICH MAY RESULT IN THE POTENTIAL FOR SERIOUS INJURY TO USERS, SPOTTERS OR BYSTANDERS.**
9. **STORING YOUR EQUIPMENT: FOR BEST MAINTENANCE, THE FLIPSLED® SHOULD BE STORED IN A DRY, DUST-FREE ENVIRONMENT. CAUTION: THE FLIPSLED® SHOULD BE STORED ONLY HORIZONTALLY AND SHOULD NOT BE STORED VERTICALLY. STORING THE FLIPSLED® VERTICALLY MAY CREATE A TIPPING RISK TO BYSTANDERS. ALWAYS ENSURE THE FLIPSLED® IS PROPERLY SECURED TO AVOID TIPPING. FAILURE TO FOLLOW THIS INSTRUCTION MAY LEAD TO SERIOUS INJURY OR DEATH.**
10. **PLEASE READ THE OWNER'S MANUAL FOR A COMPLETE LIST OF IMPORTANT INSTRUCTIONS FOR THE SAFE AND PROPER USE, MAINTENANCE AND STORAGE OF YOUR EQUIPMENT.**
11. **Do not exceed maximum load on free weight pins. Exceeding the maximum load on free weight pins may cause free weight pins to break, resulting in the potential for damage to the FlipSled® and the potential for serious injury or death.**
12. **Use caution when changing free weights on the FlipSled®.**
13. **Check to ensure that all straps, pins, locks, spotter bars and other safety devices are in place before use.**
14. **It is extremely important to adequately tighten all fasteners and components during assembly, and then before using the FlipSled® check all fasteners and components for proper tightness and lack of cracks or damage. Failure to do so could result in damage to the FlipSled® and the potential for serious injury or death.**
15. **Only drive and flip the FlipSled® on dry durable, hard surfaces (e.g., turf, grass, etc.) with good traction, using suitable footwear having good traction. Use of the FlipSled® on unstable, soft, or smooth surfaces (e.g., a gymnasium floor) is not intended and increases the potential for the FlipSled® to operate in such a way that may cause damage to flooring and serious injury to users, spotters or bystanders.**

⚠ CAUTION ⚠ ATTENTION

**This Is Not A Toy and Intended for Use By or Under the Supervision of Adults.
Ceci n'est pas un jouet et est destiné à être utilisé par ou sous la surveillance d'adultes.**

IMPORTANT SAFETY INSTRUCTIONS CONT.

5

16. Users and spotters should not lift more weight than they know they can comfortably lift.
17. DO NOT use equipment improperly or for exercises not intended.
18. Be aware of possible pinch points.
19. The FlipSled® is not a toy and is intended for use by or under the supervision of adults.
20. Use only the attachments and accessories recommended or sold by the manufacturer. The use of attachments or accessories not recommended or sold by the manufacturer may cause damage to the product and void relevant warranty protection, and also may result in serious injury or death.
21. Do not leave FlipSled® outdoors in harsh conditions for long periods of time. This may cause deterioration of components which could lead to serious injury or death.
22. If using free weights on the FlipSled®, always secure in place with the provided spring clamps.
23. Do not modify or otherwise alter any element or component of the FlipSled®.
24. Always adequately warm up.
25. Use proper form. Discontinue use if uncomfortable.
26. Do not overexert the user with any exercise program.
27. If maintenance is required, please contact the manufacturer.

⚠ CAUTION ⚠ ATTENTION

**This Is Not A Toy and Intended for Use By or Under the Supervision of Adults.
Ceci n'est pas un jouet et est destiné à être utilisé par ou sous la surveillance d'adultes.**

TABLE OF CONTENTS

6

Specifications	2
Important Safety Instructions	3-5
Table of Contents	6
General Information	7
Body Components	8
Body Assembly	9-12
Attachment Components	13
Attachment Assembly	14-15
Maintenance and Warranty	16-20
Maintenance Schedule	
Cleaning	
Registration	
Warranty Information	
Contact Information	Back Cover

GENERAL INFORMATION

7

1. Storing

For best maintenance, The FlipSled® should be stored in a dry, dust-free environment. **CAUTION: The FlipSled® should be stored only horizontally and SHOULD NOT BE STORED VERTICALLY.** Storing the FlipSled® vertically may create a tipping risk to bystanders. Always ensure the FlipSled® is properly secured to avoid tipping. Failure to follow this Instruction may lead to serious injury or death.

2. Moving

The FlipSled® can be moved with one person on a flat and level surface. If moving on an incline, two people are recommended.

3. Placement

The FlipSled® should be used on a solid, level surface.

4. Personal Safety

To reduce the risk of serious injury, read all important precautions and instructions in this manual and all warnings on the product before use. It is the responsibility of the owner to ensure that all users of this product are adequately informed of all warnings and precautions. Use the product only as described in this manual.

Airborne Athletics assumes no responsibility for personal injury or property damage sustained by or through the use of this product.

Playing football, strength training, or cross training is exercise. How you begin your exercise program depends on your physical condition. Before beginning any exercise program, consult your physician. This is especially important for persons over age 35 or persons with pre-existing health problems. Frequent and strenuous exercise should be approved by your doctor first.

Warming up is an important part of your workout and should begin every session as it reduces risk of injury. It prepares your body for more strenuous exercise by heating up and stretching out your muscles, increasing your circulation and pulse rate, and delivering more oxygen to your muscles. At the end of your workout, repeat the warm up exercises. While performing any type of exercise routine you must drink plenty of fluids. It's important to work at your own pace.

If any discomfort should result from your use of this product, stop exercising and consult your doctor.

Please keep all children away from the product when product is unattended. Adult supervision is required at all times during use of this product.

Please ensure this product is assembled and installed by adults.

5. Equipment

It is extremely important to adequately tighten all fasteners and components during assembly. Inspect the FlipSled® before use to ensure good working order. Check to ensure that all straps, pins, locks, spotter bars and other safety devices are properly in place and secured. Make sure all bolts and fasteners are tight and there are no cracks in or damage to any components of the unit before each use. Failure to do so could result in damage to the FlipSled® and the potential for serious injury or death.

6. Manufacturer Website and Updates

Please visit our website from time to time for additional information and updates on our products, usage, safety instructions and other pertinent information. Our website is (www.theflipsled.com).

BODY COMPONENTS

8

Main Frame x 1

You will receive one of the following frames depending on the model you ordered.

FS300 Frame

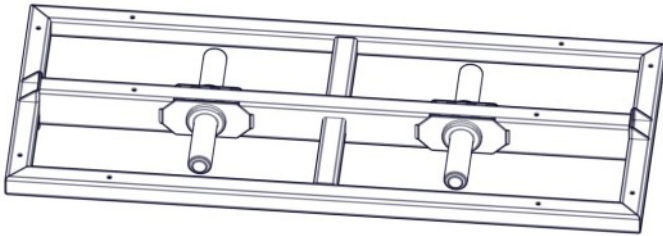

FS200 Frame

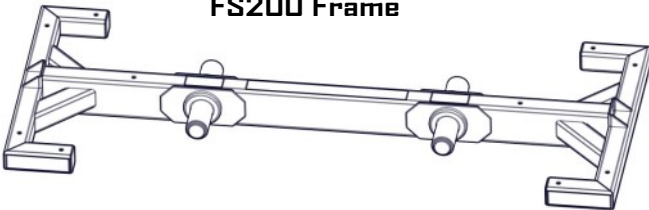

FS100 Frame

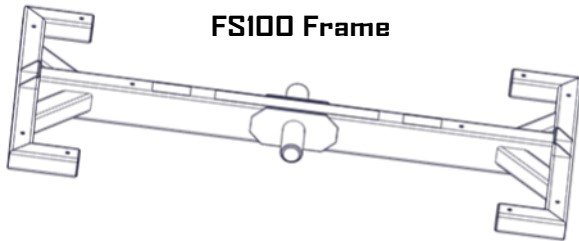

End Frame with Bumpers x 4

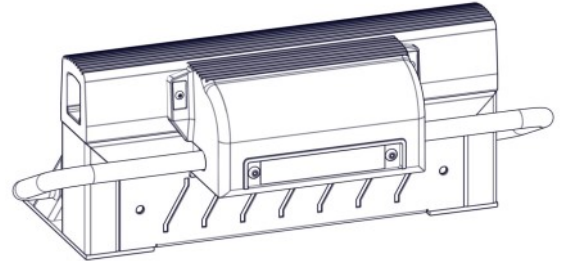

3/8" Washer x 20



Short 3/8" Nut x 2



3/8" Nut x 8



3/8" x 5" Bolt x 2



3/8" x 3.5" Bolt x 8



9/16" Wrench x 2



Spring x 4

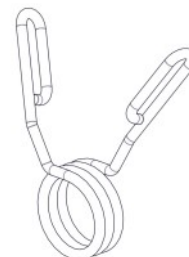

BODY ASSEMBLY

9

Assembly instructions use FS300 frame.
All frames have the same assembly process.

Helpful Notes

Assembly may be easier if you have a socket ratchet handle and 9/16" socket.

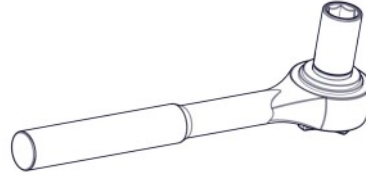

Assembly may be easier if two adults work together to align parts.

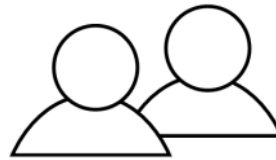

1. Bottom End Frames

Set 2 end frames with bumpers on the ground as shown. Use the main frame as a spacing guide.

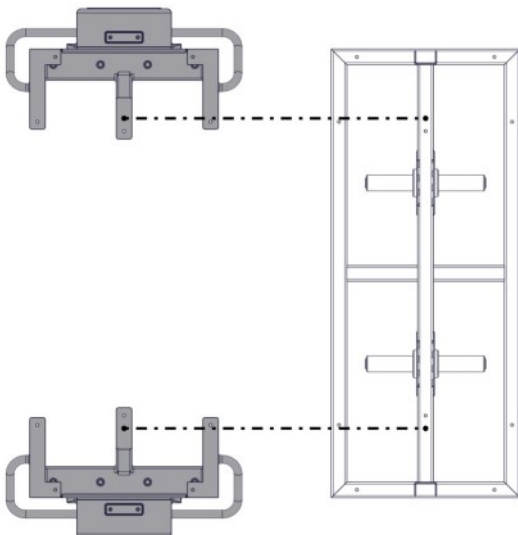
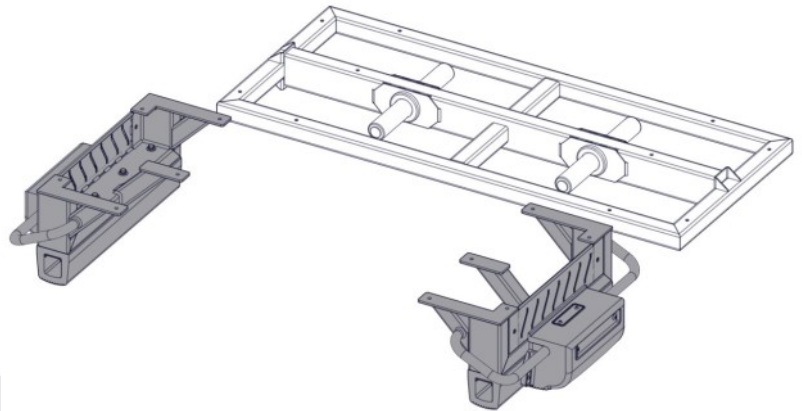

2. Main Frame

Set the main frame on top of the bottom end frames. Closely line up the holes.

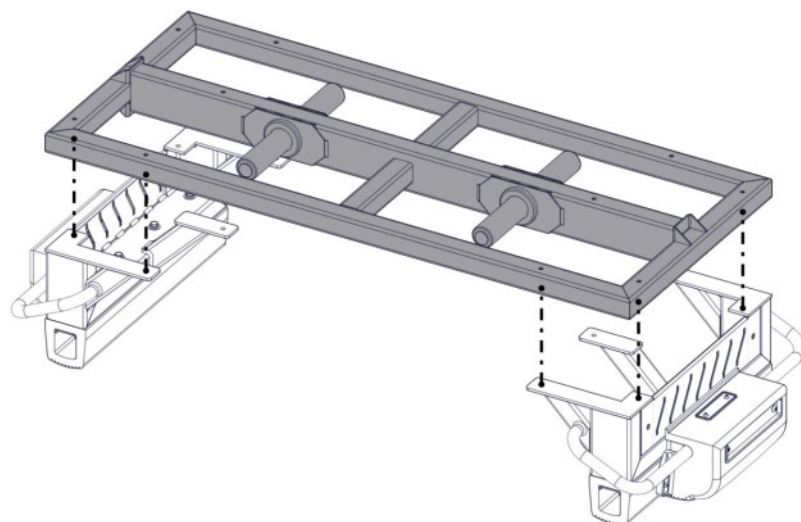

3. Top End Frames

Set 2 end frames on top of the main frame. Closely line up the holes.

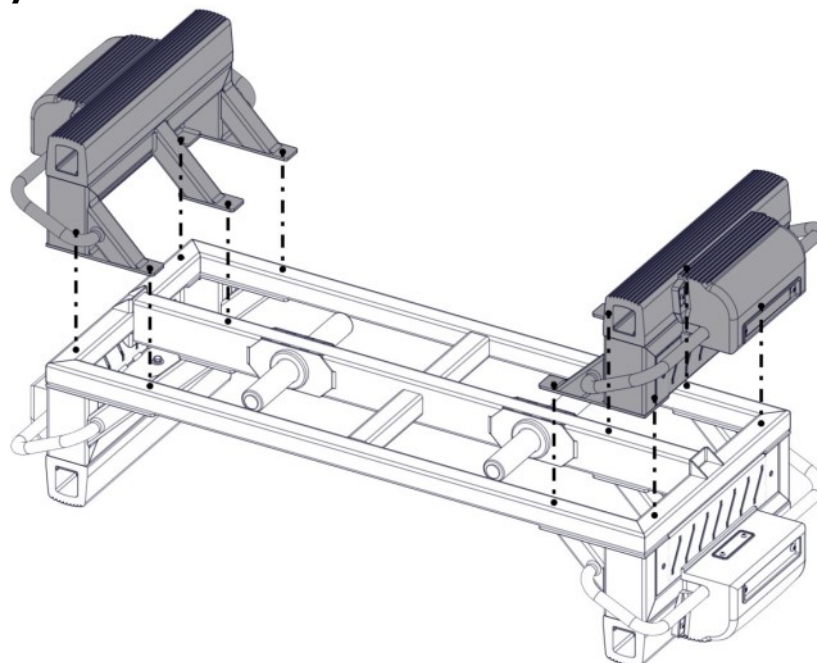

4. Bolt Outer 4 Bolts

With 4 short bolts, 8 washers, and 4 nuts, fasten the end frames to the main frame along the outer edge.

HAND TIGHTEN.

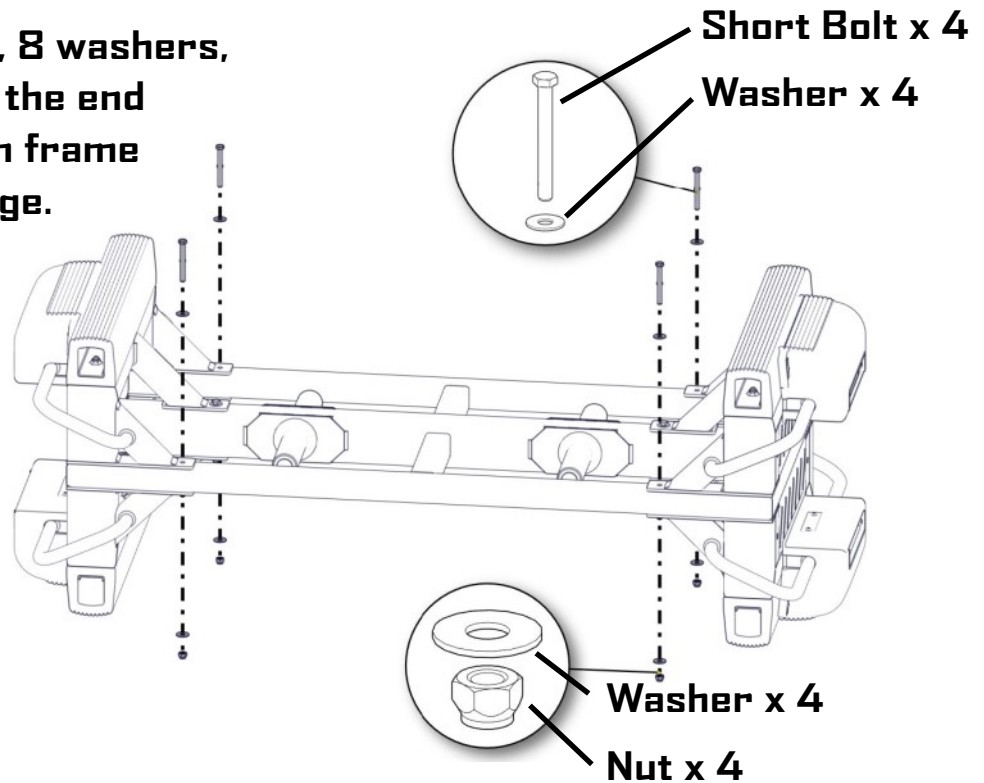

5. Bolt Middle 2 Bolts

With 2 long bolts, 4 washers, and 2 short nuts, fasten the end frames to the main frame along the middle.

HAND TIGHTEN.

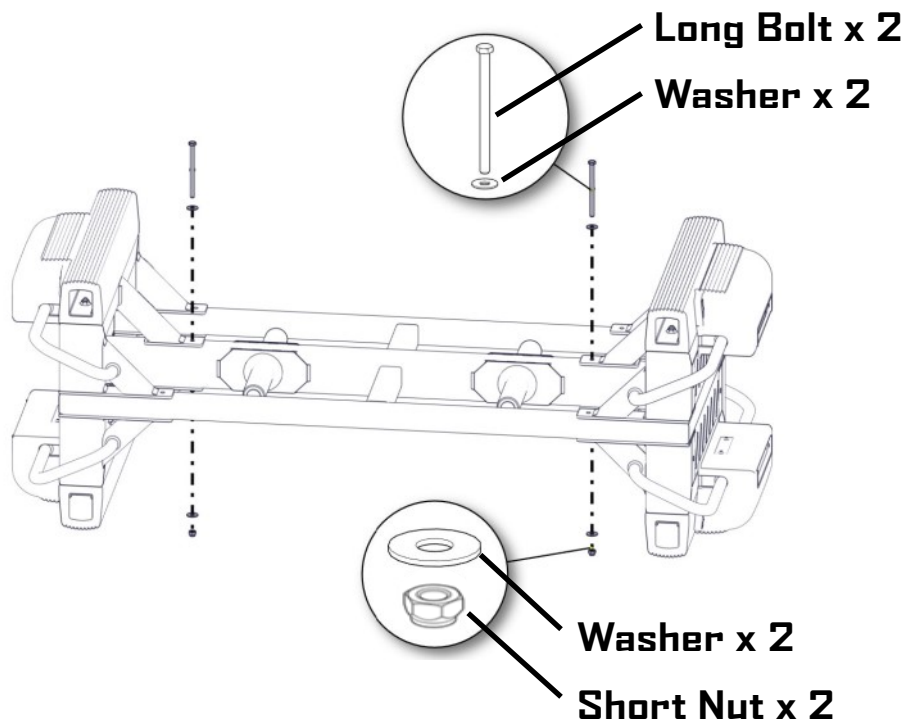

6. Bolt Inner 4 Bolts

With 4 short bolts, 8 washers, and 4 nuts, fasten the end frames to the main frame in the inside on both ends.

HAND TIGHTEN.

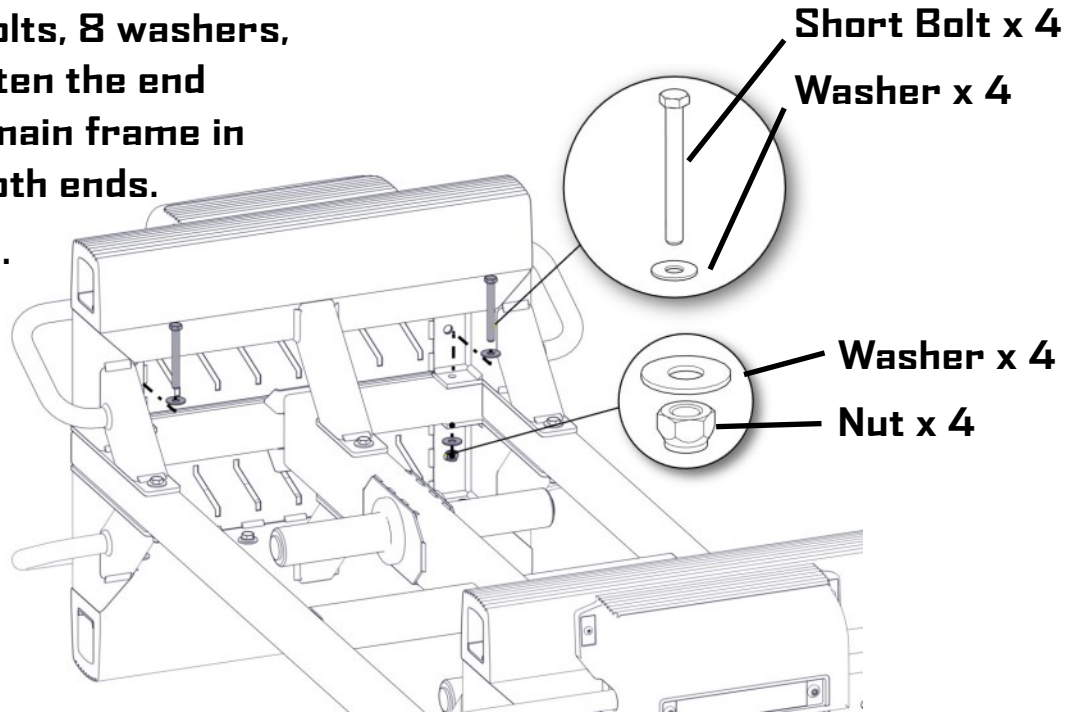

7. Tighten All Bolts

Tighten all 10 bolts.

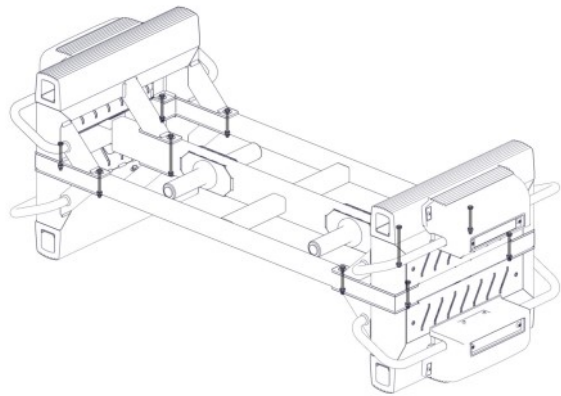

8. Install Springs

Store springs on inner posts.

Use springs to secure free weights.

Do not exceed free weight max per pin displayed on your unit.

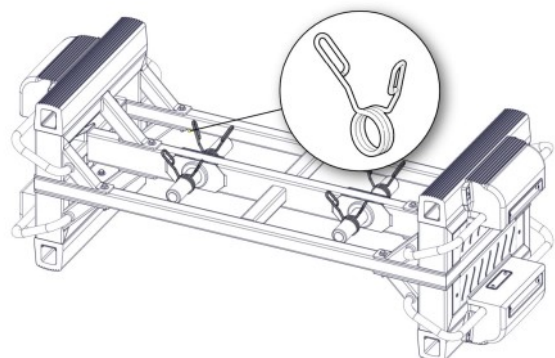

ATTACHMENT COMPONENTS

13

Sled Receiver Frame x 2

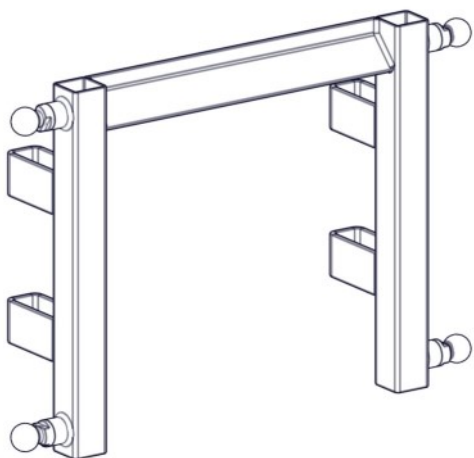

3/8" x 1" Bolt x 8

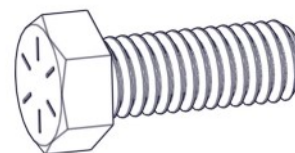

Handle x 4

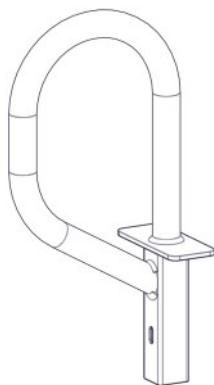

3/8" Washer x 8



Ski x 4

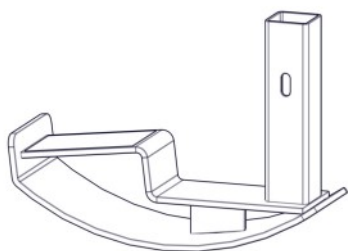

9/16 Wrench x 1



NEVER DROP OR FLIP ONTO SKIS

ATTACHMENT ASSEMBLY

14

Assembly instructions use FS300 frame.
All frames have the same assembly process.

Helpful Notes

Assembly may be easier if you have a socket ratchet handle and 9/16" socket.

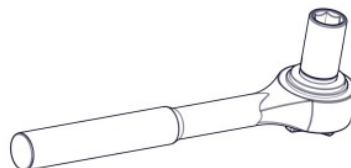

Assembly may be easier if two adults work together to align parts.



1. Place Sled Receiver Frame

Place the sled receiver frame at about a 45° angle inside the main frame.

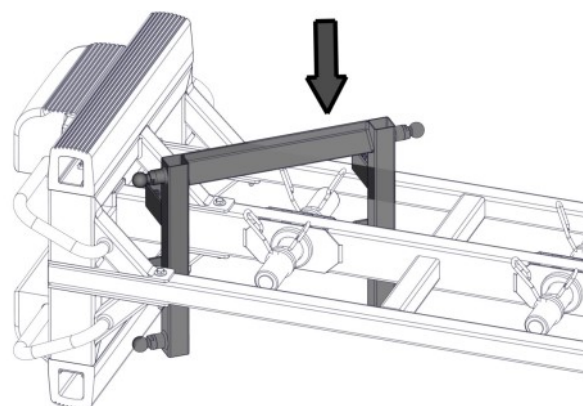

2. Rotate Sled Receiver Frame

Rotate sled receiver and align with holes in the end frame.

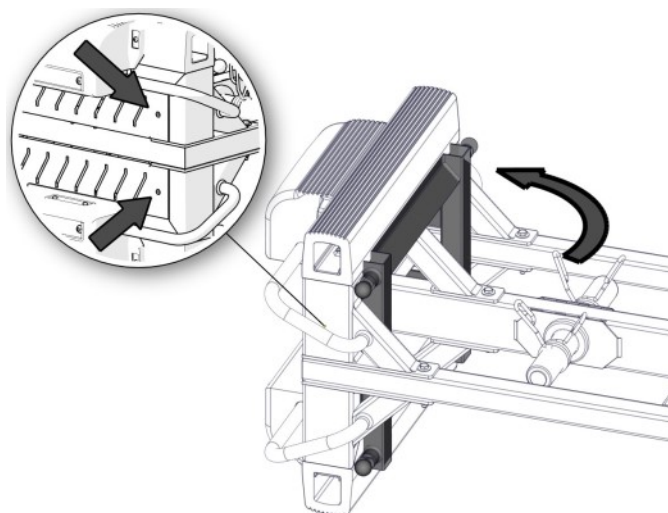

3. Bolt Together

Loosely screw in the bolts and washers to attach the sled receiver.

When all 4 bolts have been installed on one side, tighten all bolts.

Repeat for other side.

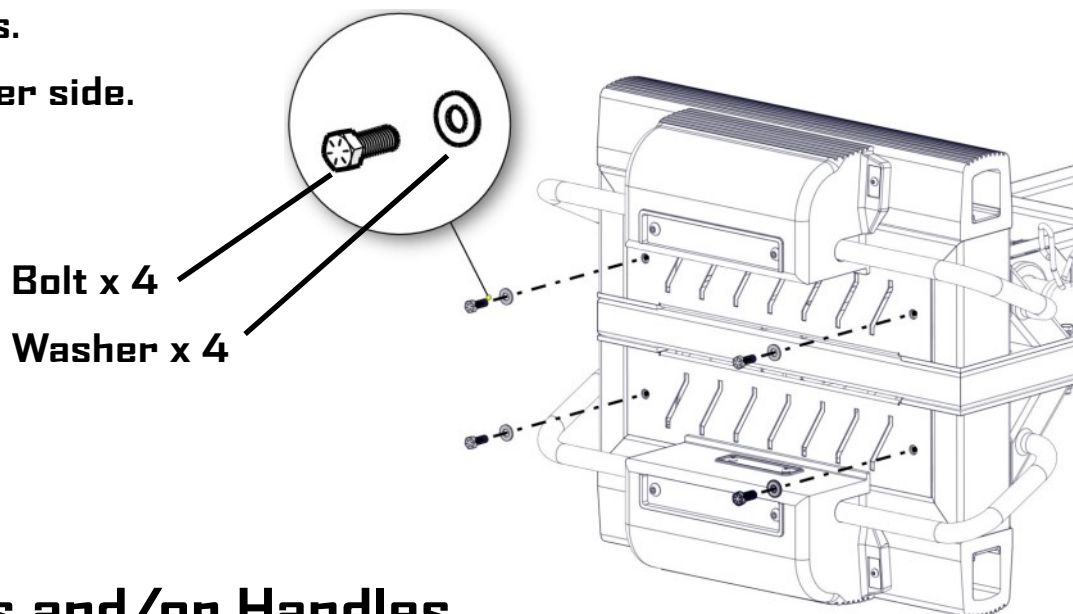

4. Install Skis and/or Handles

Pull knob out and drop in accessory. Release handle. Attachment should be secure.

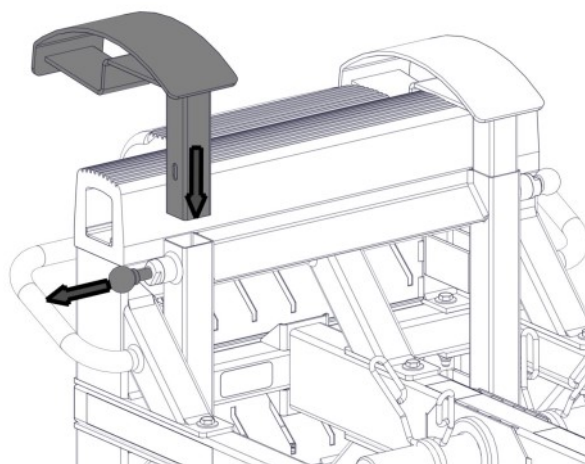

After installing ski's, GENTLY roll over.

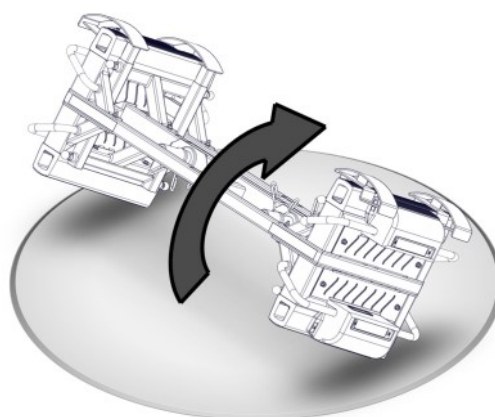

NEVER DROP OR FLIP ONTO SKIS

MAINTENANCE AND WARRANTY

16

Maintenance Schedule

The FlipSled® is designed to be virtually maintenance-free. If maintenance is required, please contact manufacturer.

Cleaning

Use a damp cloth to wipe exterior free of device of dust and residue.

Registration

Complete registration form at thefinisher.com/register to ensure proper warranty coverage.

Warranty

Who does this warranty cover?

This limited warranty (the "Warranty") is issued by Airborne Athletics, Inc. ("Airborne Athletics", "we", or "us") to you, a purchaser who purchased a new or factory refurbished FlipSled® or new FlipSled® branded accessories directly from us. The Warranty covers only you, the original product purchaser. The Warranty cannot be assigned or transferred to any subsequent purchaser or user and is not available to products that were purchased from any source other than Airborne Athletics or an authorized dealer.

What does this warranty cover?

This Warranty covers defects in the product you purchased from an authorized Airborne Athletics retailer (the "Product") as follows. Airborne Athletics warrants that the Product is free from defects in materials and workmanship and will, under normal and intended use, function substantially in accordance with our Product documentation and technical specifications. Proof of Product purchase is required as a condition to coverage under this Warranty.

MAINTENANCE AND WARRANTY

Warranty Continued

What is not covered by this warranty?

Regardless of the above, the Warranty does not cover the following:

Normal wear and tear.

Defects or malfunctions experienced during or caused by use not in conformity with Product documentation and technical specifications.

Damage caused by misuse, accident, neglect, abuse, alteration, improper or unauthorized modification, or tampering.

Damage to your property, home, walls, or floors that may result from installation or removal of the Product.

Product that has been resold.

Damage caused by improper or incorrectly performed maintenance or repair.

Damage caused by improper installation, relocation, or uninstallation.

Damage caused during shipping or delivery

Product or Product parts returned without a Return Material Authorization (RMA) number.

What is the warranty period?

The Warranty period begins the date the Product is shipped and lasts for the period specified below for the applicable Product:

Product	Warranty Period
FS-100 FS-200 FS-300	5 year coverage for parts and standard domestic shipping of said parts. Labor not included. Rubber parts have a 1 year
FlipSled® Accessories	1 year coverage for parts and standard domestic shipping of said parts. Labor not included.

MAINTENANCE AND WARRANTY

18

Warranty Continued

How do you submit a claim?

Call 952-222-7615, or email info@theflipsled.com to report any Product issues and open a claim under the Warranty. Our team will reach out to you to attempt to help resolve your issue.

If your Product has a defect or malfunction covered by this Warranty, Airborne Athletics will repair, replace, or refund the Product at the sole discretion of Airborne Athletics. If Airborne Athletics determines that a Product should be replaced, the replacement may be a new or a re-manufactured Product. Airborne Athletics may not return the original Product to you.

Do not return any Product to Airborne Athletics without first receiving a Return Material Authorization (RMA) number and instructions for how to proceed. Airborne Athletics may require you to furnish proof of purchase and/or comply with other requirements before receiving Warranty service.

What law governs the warranty?

The laws of the State of Minnesota, USA, govern this Warranty, without giving effect to any conflict of laws principles that may provide the application of the law of another jurisdiction.

AIRBORNE ATHLETICS EXPRESSLY DISCLAIMS ANY AND ALL OTHER WARRANTIES, BOTH EXPRESS AND IMPLIED, INCLUDING ANY WARRANTY OF MERCHANTABILITY OR FITNESS FOR A PARTICULAR PURPOSE.

MAINTENANCE AND WARRANTY

19

Warranty Continued

AIRBORNE ATHLETICS AND ANY THIRD-PARTY SERVICE PROVIDERS OR SUPPLIERS SHALL NOT BE LIABLE FOR PERFORMANCE DEFICIENCIES CAUSED OR CREATED BY YOU OR OTHERS YOU ALLOW TO USE THE PRODUCT. AIRBORNE ATHLETICS DOES NOT WARRANT THAT ITS EQUIPMENT'S PERFORMANCE WILL BE UNINTERRUPTED, ERROR-FREE OR COMPLETELY SECURE. AIRBORNE ATHLETICS AND ANY THIRD-PARTY PROVIDERS OR SUPPLIERS SHALL NOT BE LIABLE FOR SERVICE INTERRUPTIONS CAUSED BY FAILURE OF EQUIPMENT, OTHER SOFTWARE OR SERVICES NOT PROVIDED BY AIRBORNE ATHLETICS OR ITS THIRD-PARTY PROVIDERS OR SUPPLIERS, OR FAILURE OF COMMUNICATIONS, POWER OUTAGES, OR OTHER INTERRUPTIONS NOT WITHIN THE COMPLETE CONTROL OF AIRBORNE ATHLETICS OR ITS PROVIDERS OR SUPPLIERS, EVEN IF AIRBORNE ATHLETICS OR ITS THIRD-PARTY PROVIDERS OR SUPPLIERS KNOW OR HAVE BEEN ADVISED OF THE POSSIBILITY OF SUCH LOSS. IN THE EVENT OF ANY SYSTEM ERROR OR OMISSION, THE SOLE OBLIGATION OF AIRBORNE ATHLETICS SHALL BE TO PROCESS A CORRECTION OF THE ERROR OR OMISSION AS REASONABLY NECESSARY.

MAINTENANCE AND WARRANTY

20

Warranty Continued

AIRBORNE ATHLETICS DOES NOT ASSUME ANY LIABILITY FOR ANY SPECIAL, INDIRECT, INCIDENTAL, PUNITIVE, OR CONSEQUENTIAL DAMAGES OF ANY KIND WHATSOEVER, INCLUDING BUT NOT LIMITED TO LOSS OF PROFITS OR REVENUES, LOSS OF DATA, LOSS OF USE OF THE PRODUCT, COST OF REPLACEMENT OR SUBSTITUTE ITEMS, OR LOSS OF USE DURING THE PERIOD THAT THE PRODUCT IS BEING REPLACED OR REPAIRED. FURTHER, AIRBORNE ATHLETICS SHALL NOT BE LIABLE TO YOU FOR ANY SPECIAL, CONSEQUENTIAL, INCIDENTAL, INDIRECT, OR PUNITIVE DAMAGES OF ANY KIND WHATSOEVER, EVEN IF AIRBORNE ATHLETICS HAS BEEN ADVISED AS TO THE POSSIBILITY OF SUCH DAMAGES, FOR ANY CLAIM ARISING FROM OR RELATED TO THIS WARRANTY STATEMENT, REGARDLESS OF THE FORM OF ACTION, WHETHER IN CONTRACT, TORT (INCLUDING NEGLIGENCE), PRODUCT LIABILITY, LOST REVENUE, LOST PROFIT, LOST DATA, OR PRIVACY, OR ANY OTHER CAUSE OF ACTION OR LEGAL OR EQUITABLE THEORY. IN NO EVENT SHALL AIRBORNE ATHLETICS'S LIABILITY FOR ANY CLAIM ARISING OUT OF OR RELATED TO THIS WARRANTY EXCEED THE PRICE PAID BY YOU FOR PURCHASE OF THE PRODUCT, REGARDLESS OF THE FORM OF ACTION, WHETHER IN CONTRACT, TORT (INCLUDING NEGLIGENCE), PRODUCT LIABILITY, LOST REVENUE, LOST PROFIT, LOST DATA, OR PRIVACY, OR ANY OTHER CAUSE OF ACTION OR LEGAL OR EQUITABLE THEORY.

More Questions?

If you have questions, or to begin the service process, please contact us at info@theflipsled.com

CONTACT INFORMATION

Be Better Every Day™

21



Online: www.theflipsled.com

Fax: 952-443-8485

Phone: 952-222-7615

Email: info@theflipsled.com

Mail: 1701 W 94th St, Suite 225
Bloomington, MN 55431



Follow us on Facebook, Instagram, Twitter, & YouTube



www.TheFlipSled.com

FlipSled® Rev M